

# Dual Flow Feeders

## Double Your Tunnel Capacity

Consider the opportunity of increasing your flow from 1200 tons per hour to 2400 tons per hour. The VSS Macropaver Dual Flow Feeder Line of products is specifically designed to keep your materials moving. Dual Flow Feeders allow high production rates in tight spaces due to the low profile design. We recognize that if your material flows, so does your cash.

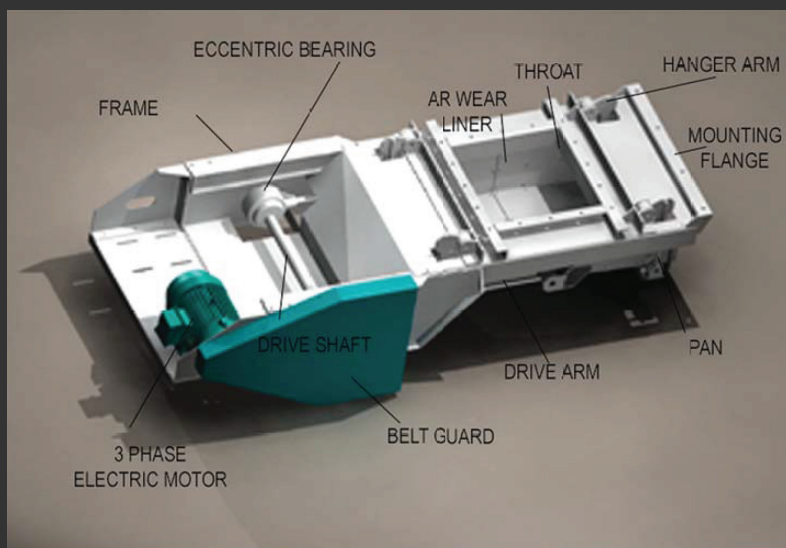

### FEATURES:

- The Dual Flow Feeder is shipped completely assembled.
- Feed rates accurately determined by the speed and easily controlled by standard motor controls.
- The feed rate of the Dual Flow Feeder is accurately controlled either locally or remotely.

# DUAL FLOW FEEDER SPECIFICATIONS

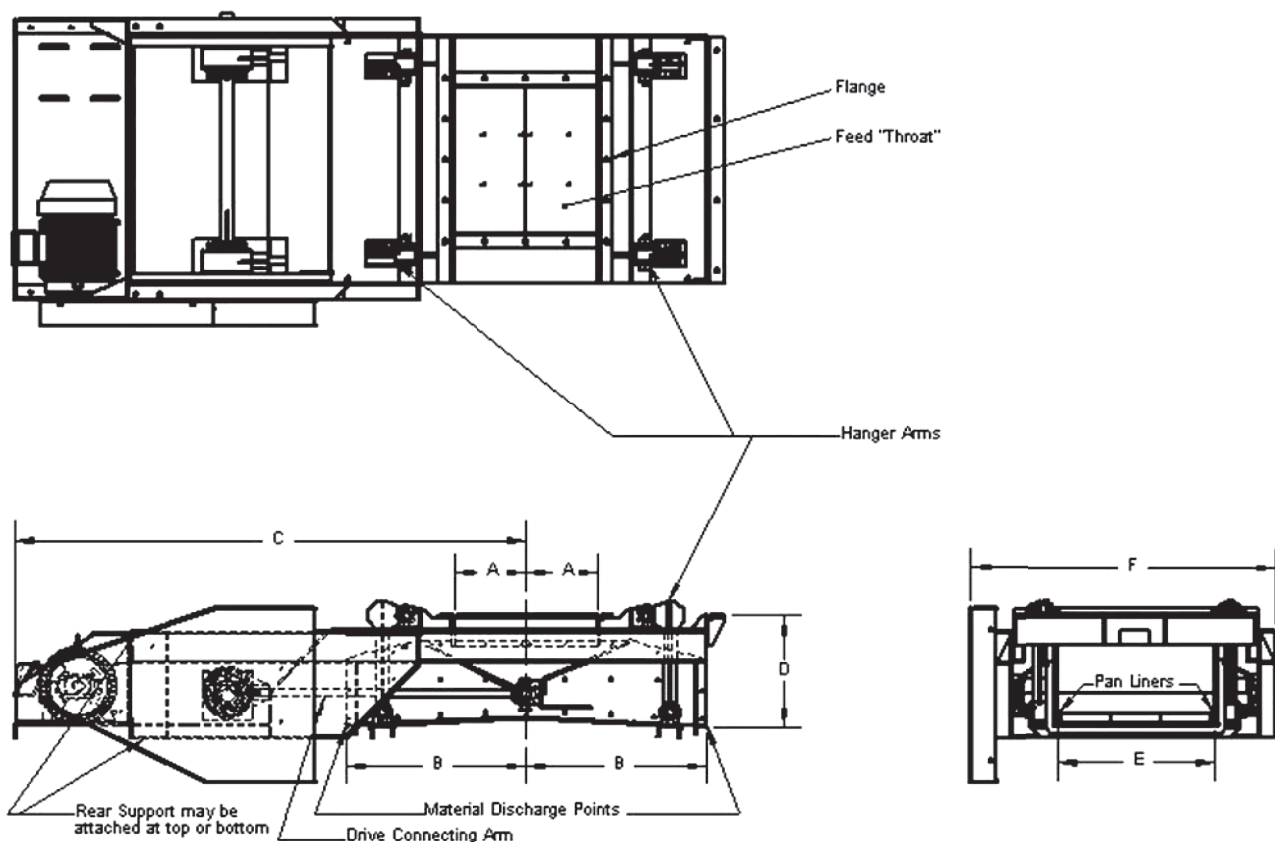

MODEL	Cap(tph)	Hp	A	B	C	D	E	F	Weight
18DF	450	5	9	24	76	15¼	21	42¾	1800
24DF	810	7.5	12	30	85	18½	26	50¾	2400
30DF	1260	10	15	39	99	25	31¾	56¾	3900
36DF	1820	15	18	45	102¾	26½	38½	67	4700
42DF	2420	20	21	53	120½	28½	46	81¾	8600

**Applications:** Dual Flow Feeders discharge material in two equal streams instead of one large one. This patented design gives Dual Flow Feeders a low profile and dramatically reduces their size and weight, making them ideal for us in reclaim tunnels and other applications where space is limited. Their compact size allows you to easily replace an existing feeder with a Dual Flow Feeder.



U.S. and International Patents Pending  
VSS reserves the right to make changes in specifications at any time as part of our continuing program of product improvement. © 2020